

Holographic Developer and Bleach  
Chemistry Test Results  
for the  
Endoscope Application

Tests conducted by  
Salim F. Idriss and Ed Wesley  
Report compiled by Salim F. Idriss  
Department of Biomedical Engineering  
Northwestern University  
Evanston, Illinois  
June-August 1986

## I. Introduction

Tests were made with three types of holographic setups in order to optimize the developer, bleach, and exposure combinations for each configuration. Denisyuk type reflection holograms were made with both a continuous wave He-Ne laser and a pulsed ruby laser. Also, pulsed ruby transmission holograms were made. The criteria for the evaluation of the test were based on the endoscope application; however, the results could be applied to other projects as well.

## II. He-Ne Denisyuk Tests

The initial experiments were performed using a 5mW Melles Griot He-Ne c.w. laser. A Denisyuk type reflection configuration was assembled as shown in Fig.1a using the test object shown in Fig.1b. Energy measurements were made with a United Detector Technology 61 digital optometer. At the object surface, the hot spot in the expanded beam was measured at 24 uW/cm-cm. Using Agfa-Gevaert Holotest 8E75 4"x5" emulsion plates (#598209V), exposures were made in quadrants at 5,10,20, and 40 seconds. This corresponds to energies of 120,240,480, and 960 uJ/cm-cm at the plate surface. After exposure, the plates were developed in various developers. Seven different developer chemistries were used (Appendix A); these were Cooke and Ward CWC2, Ilford, Pyrochrome, Original Holodev 602, Improved Holodev 602, Original Holodev 602 with Pyrocatechol, and Improved Holodev 602 with Pyrocatechol. Development times and temperatures varied with each developer in order to maintain a constant developing density for the wide range of chemistries-- see Appendix C. After developing, the plates were washed in 68 of running tap water for 3 min. Bleaching was then performed with five different chemistries (Appendix B). Pyrochrome(diluted 1:4), Cooke and Ward CWPBQ2, Ilford, Holo, and N.J. Phillips' Ammonium Dichromate bleaches were used. Bleaching was continued until the plate cleared. The plates were then washed again in running tap water for 5 min. and finally rinsed in Photoflo for approximately 2 min. before final drying.

The criteria for the evaluation of the holograms were based on several aspects of the reconstruction. For the rehalogenating bleaches (Ilford, Holo, CWPBQ2), the plates were replaced in their original positions and reilluminated with He-Ne laser light. Attempts were then made to observe real-time fringes after manipulation of the plate. The coarsest possible fringe patterns were to be observed; these would indicate the most exact reconstruction and wavelength replay. Also, signal-to-noise and diffraction efficiency were qualitatively judged. The reversal bleach plates (Pyrochrome, N.J. Phillips) were observed with white light. As before, SNR and efficiency were qualitatively judged as well as color and resolution. Shrinkage of the emulsion was desired, and a light golden color was taken as the best exposure. Finally, speed was taken into account because tests would be conducted with a pulsed ruby laser with a 20 ns pulse.

It was found that two developers performed as desired. In addition, one reversal bleach and one rehalogenating bleach were found to be optimum when used with each of these developers. The Cooke and Ward

Fig 1a Dasaryuk setup for He-Ne c.w. testing

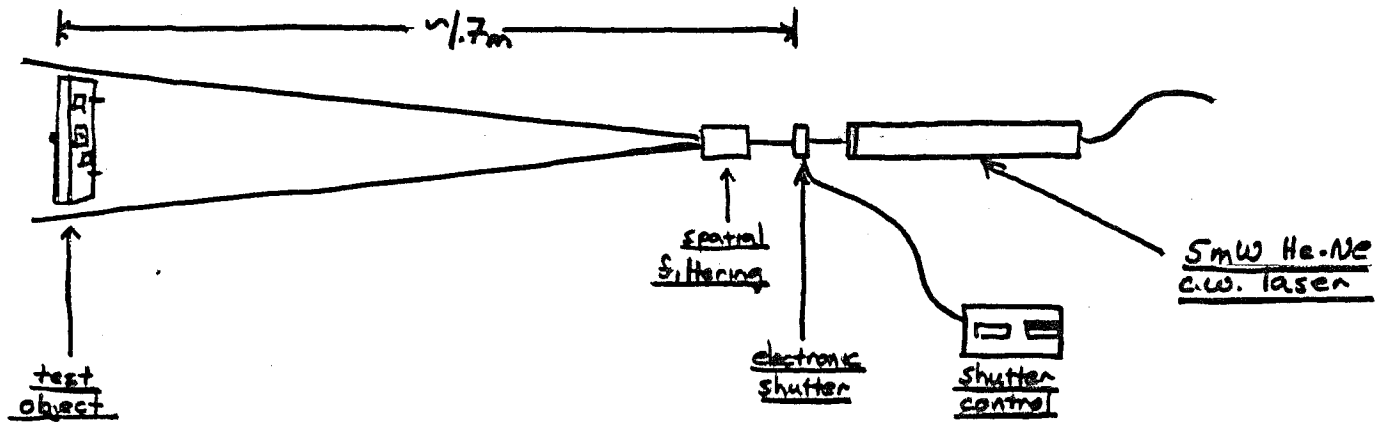
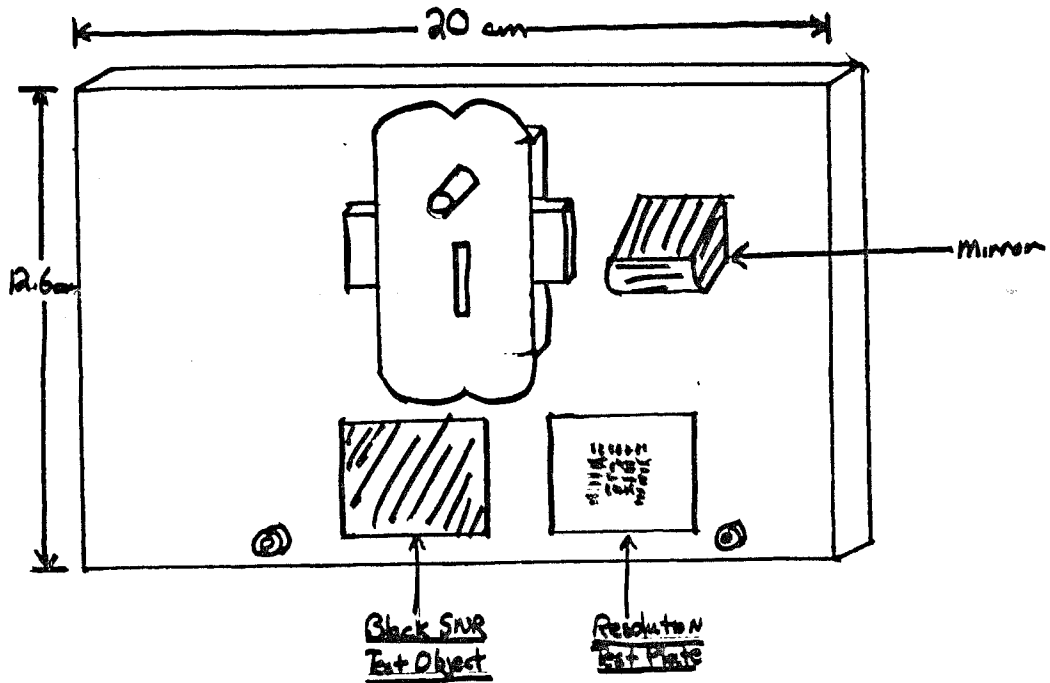

Fig 2b Test Object



developer (CWC2) worked the best overall. For white light reconstruction, Pyrochrome reversal bleach in conjunction with CWC2 gave the best holograms at an exposure of 10" (240 uJ/cm-cm). Golden-yellow holograms were obtained which were very efficient and high in resolution relative to the other combinations. As expected with bleached reflection holograms, the amount of noise was high; however, the CWC2 gave relatively less noisy results. For He-Ne laser reconstruction, CWC2 developer again gave the optimum results when used with a variety of bleaches. At a 20" exposure (480 uJ/cm-cm), CWC2 worked with Ilford, Holo, and CWPBQ2 bleaches to give efficient, resolute, and less noisy holograms. Reconstruction was considered exact due to the ease of observing real-time fringes. The CWC2 performed the best with its own bleach CWPBQ2; however, considering the hazards of contact with the p-benzoquinone solution, the Holo bleach or the Ilford formula should be used to give the desired results at less risk.

The second developer that worked well was Holodev 602 (original formula). As with the CWC2, Holodev gave excellent white light reconstruction when used with Pyrochrome bleach at a 10" exposure. The color, efficiency, and noise were as desired. Qualitatively, the Holodev results were almost the same as with CWC2. Once again, for laser reconstruction, three bleaches worked well with the developer. Holodev 602 gave good holograms with Holo, Ilford, and CWPBQ2 bleaches at a 20" exposure. Holo bleach and the Ilford formula are considered the best choices as was previously explained.

Due to the necessity for using low power with the pulsed ruby laser in the endoscope application, some experiments were performed in the area of liquid hypersensitization. A Pyrogallol/Phenidone solution was mixed, and 4"x5" 8E75 plates were half-dipped for two minutes and allowed to dry 24 hours. Exposures were then made at two and five seconds, and the plates were processed in the usual manner with Holodev 602 and Pyrochrome bleach. The 5" exposure (120 uJ/cm-cm) had high efficiency and resolution. However, the reconstruction was in the green wavelength. The emulsions were assumed to be swelled at the time of exposure and then shrunk with the bleaching process. A step increase in speed was achieved; yet, considering the difficulties involved with the liquid process and considering the undesired color at reconstruction, this method was not deemed usable for the desired application.

A final note is to be made concerning the continuous wave He-Ne laser tests. The Cooke and Ward developer-- CWC2-- performed extremely well, and Holodev 602 was almost as good. For use with the Pyrochrome bleach, both developers functioned best with a 10" exposure (240 uJ/cm-cm). Also, their results were almost identical with the rehalogenating bleaches at a 20" exposure (480 uJ/cm-cm). However, CWC2 was used at 20 oC for two minutes, and Holodev 602 was at 26 oC for three minutes. Tests of pH were made of the developers, yet there was not enough variation to make any correlations between pH and performance. Holodev 602 has more pyrogallol than any of the tested developers-- as well as a large amount of sulfites; perhaps, Holodev has an excess of chemicals and therefore must be heated to function properly. More experimentation should be done in order to determine the reasons for the developer's performance. The Improved 602 developer had poor results compared to the original formula. Since the phenidone concentration was decreased in the improved version, this chemical can

be considered important for performance-- as will be discussed later. The results of all the He-Ne laser tests are detailed in Appendix C.

### III. Pulsed Ruby Transmission Tests

The next set of experiments were performed to find the optimum developer and bleach combinations for transmission holograms with a pulsed ruby laser. A transmission setup was assembled as shown in Fig.2 with a JK System 2000 pulsed ruby laser and using the test object in Fig.1b. A single beam type setup was used, and the reference to object beam ratio was manipulated to be 4:1 as determined with a He-Ne laser alignment beam. The beam diameter at the object surface was determined to be approximately 30cm-- this corresponds to an area of 706.9cm-cm. Energy measurements of the ruby pulse were taken at the output of the amplifier and are shown in the following table:

Q-SWITCHING----Oscillator Setting-180 Delay-300

<u>AMP POWER</u> <u>SETTING</u>	<u>ENERGY</u> (mJ)	<u>CALCULATED ENERGY</u> <u>AT OBJECT</u> (uJ/cm-cm)
170	100	141
180	120	158
190	270	355
200	340	447
210	480	631
220	410	539
230	520	683
240	720	946
250	740	973

(these are single rough readings--not averages)

Three developers were tested for their performance in producing high quality pulsed transmission holograms. Neofin Blue, Pyrochrome Plus, and Improved Holodev 602 developers were tested; bleaching was with Ferric Nitrate Bleach. Tests were also performed to determine the best combinations of fixing and bleaching.

Plates were exposed with the ruby pulse with Q-switching. The oscillator voltage was set at 180, and the amplifier voltage was at 170-- as previously determined to be the best exposure for these developers. Neofin Blue was used at 26 oC, and the development time was 1' 20"-- the desired plate density was obtained after this period. Pyrochrome Plus and Improved Holodev were also at 26 oC; however, the development times were varied in order to maintain a constant plate density. The Pyrochrome Plus formula took two minutes to reach the density; Improved 602 never reached the full density and developing was halted after five minutes. The processing was continued in the normal manner. It was assumed that Neofin Blue would give the best results, but extra tests were also performed to determine the best fixing/bleaching combination for the Neofin Blue developer.

The results showed that Neofin Blue did indeed produce the highest quality pulsed transmission holograms. The resolution and diffraction efficiency were very high-- the low SNR complimented these elements. Improved 602 and Pyrochrome Plus both worked and gave good results. The

Fig 2. Transmission Setup for Pulsed Ruby Tests

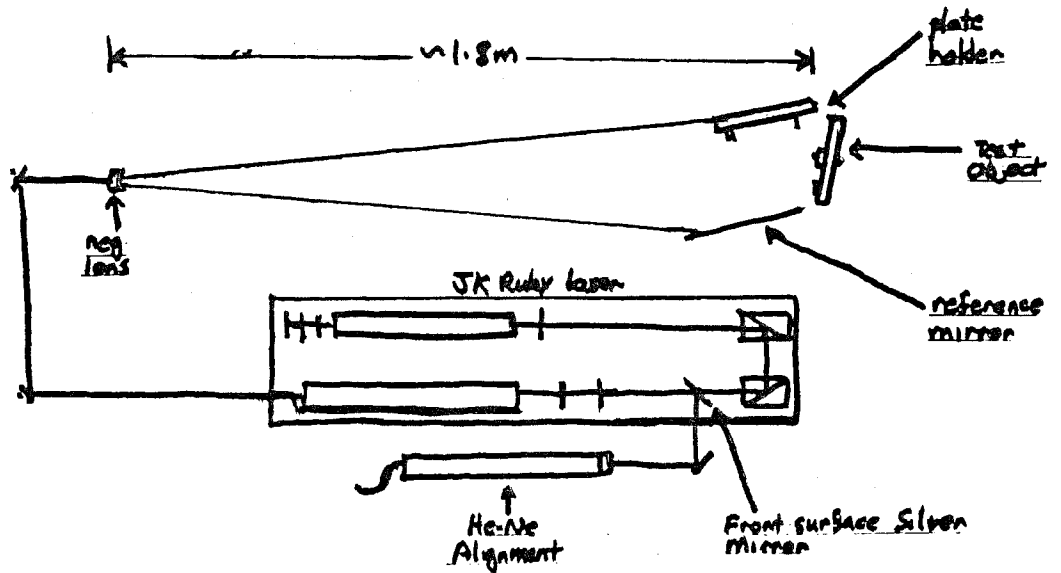
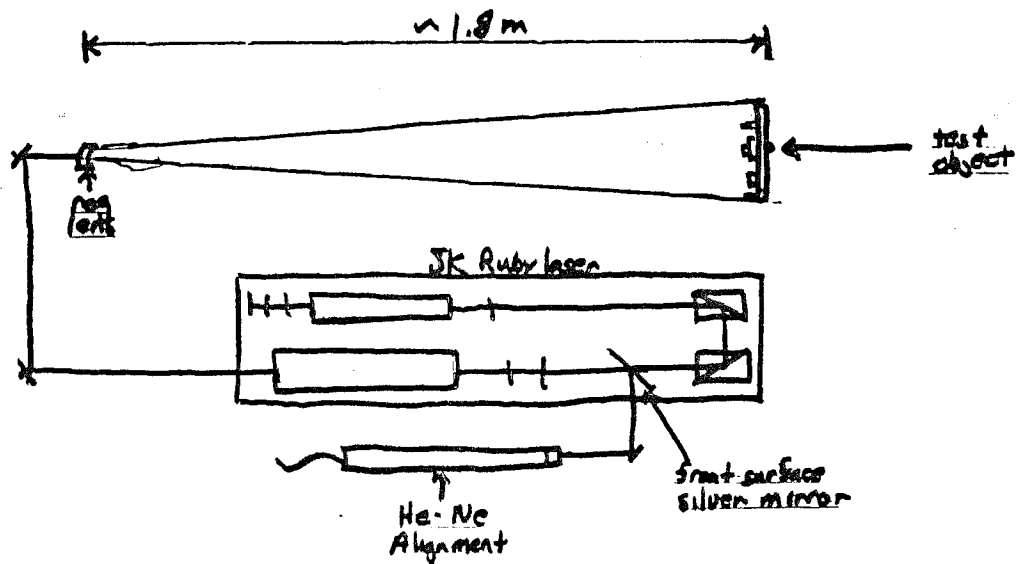

Fig 3. Denisyuk Setup for Pulsed Ruby Tests



Improved 602 holograms had sufficient resolution and were fairly bright. Also, the Pyrochrome Plus formula produced bright holograms, but the resolution was down-- almost a blurry image. Overall, Neofin Blue functioned the best. It was found that the fixed/bleached plate was more efficient than any of the other combinations-- this was as expected. The unfixed/bleached plate gave the next best results. As a final note, it was discovered that there was a slight amount of contouring in some of the holograms-- a few low contrast fringes were observed. To correct the problem, the oscillator voltage was dropped to 175 instead of 180; tests were then made, and the contouring disappeared.

#### IV. Pulsed Ruby Denisyuk Tests

The last tests to be performed were the most astonishing. A Denisyuk type reflection setup was assembled using the JK pulsed ruby laser as shown in Fig.3. The single beam setup used the same test object as in Fig. 1b. Using the He-Ne alignment beam, it was determined that the beam diameter at the object surface was approximately 30cm-- corresponding to an area of 706.9cm-cm. The output energies were assumed to be the same as with the transmission setup. The tests were made with Q-switching with the oscillator voltage set at 175. Some free-lasing tests were made-- these showed almost identical results as with Q-switching. It was noted that the amplifier delay setting needed to be varied for Q-switching and free-lasing. Q-switching uses a delay of 300, whereas free-lasing gave its peak energies when the delay was set at 100.

An exposure test series was taken by varying the amplifier power. Plates were exposed with quadrants of 170, 190, 210, and 240. The first half of the testing was with three developers. Plates were developed in Neofin Blue, Holodev 602(original), and Improved Holodev 602 for their respective times. The processing was in the usual manner and bleaching was with the Pyrochrome formula. It was noticed that all the plates were very dense after being developed and seemed far overexposed. After drying, the holograms were evaluated using the same criteria as with the He-Ne laser tests.

It was found that all the plates reconstructed in white light and He-Ne laser light. However, all the holograms were extremely inefficient and reconstructed in the deep red of the ruby wavelength. Holodev 602 and Neofin Blue gave very poor results and can be ignored for this aspect of the testing. Improved 602 produced the best results of the three; however, the quality was far from the desired. It was noticed that the 210 and 240 quadrants were overexposed. A test series was shot with quadrants of 130,150,170, and 190, and it was seen that 130 and 150 were underexposed. These are interesting results because they show that there is a peak exposure that must be reached. If exposures are made beyond the peak, then solarization occurs and the plates are burnt out. For Improved 602, the best exposure was at 170-- yet these were no where near the He-Ne c.w. tests.

Because of the reconstruction at a longer wavelength than the desired, some attempts were made at shrinking the emulsion and increasing the speed as well. Once again, liquid hypersensitization was attempted. Plates were dipped in the Pyrogallol/Phenidone solution, and also some plates were dipped in 2% triethanolamine to swell the

emulsion. As a final step, a normal plate was exposed and processed-- except bleaching was with full strength Pyrochrome. None of these tests produced the required results. The most obvious result was an extreme increase in the noise. Once again, liquid hypersensitization can be excused as a reliable method in this application.

Finally, two more developers were to be tested. The Cooke and Ward formula(CWC2) and the Benton formula(PAAP) were tested with the pulsed reflection setup. The magic begins here. During the mixing of the PAAP formula, twelve times more phenidone was accidentally added-- 6g instead of .5g. A test series was shot with quadrants of 190,210,230, and 250 with the new solution. Processing was completed as usual with the Pyrochrome bleach after two minutes of developing. All four quadrants were burnt out due to solarization. However, where the exposure blocker had been and where there was little exposure, a small amount of diffracted light could be seen. The peak had been passed. Another test series was shot which included the 150 and 170 settings. The 170 quadrant turned out perfect! The resolution and efficiency were surprisingly good compared to the previous tests. Also, the color was a yellowish-orange like the He-Ne tests. White light and He-Ne laser reconstructions were both possible and of high quality. As a double check of the new formula's magic, tests were made with other developers. The original PAAP, PAAP with 1.5g phenidone, CWC2, and Improved Holodev602 with 6g phenidone were tested. They all gave inferior results. The new developer was renamed as SM-6 for this author's mistake of 6g phenidone.

As a conclusion, some notes must be made. SM-6 fulfills all the desired requirements for the endoscope application. Bright pulsed reflection holograms can now be obtained which reconstruct in the He-Ne light and also give a desirable color in white light. As stated before, phenidone is an important developing agent. However, it also needs the proper chemical environment as shown with the Holodev formulas-- adding more phenidone did not increase their performance. It also should be noted that ascorbic acid plays a vital role as well. CWC2 and SM-6 both have it and give promising results. Tests should be done with the straight Vitamin C developer AAP. Finally, it will be very interesting to see if SM-6 will give the same optimum results with the transmission setup as well as with beam transmission through fibers. As an aside, one test was performed which tested SM-6 with the He-Ne c.w. laser. It was observed that the new formula didn't give the good results as with CWC2 or Holodev 602-- too bad.



APPENDIX A

DEVELOPER CHEMISTRIES

---

Pyrochrome-----2'at 20oC

PART A

Pyrogallol--10g  
Water-----1liter

PART B

Sodium Carbonate--60g  
Water-----1 liter

---

Pyrochrome Plus-----2'at 20oC

PART A

Pyrogallol--20g  
Phenidone---1.5g  
Water-----1 liter

PART B

Sodium Carbonate--120g  
Water-----1 liter

---

Ilford-----3'at 20oC

PART A

Pyrogallol----12g  
Ascorbic Acid--12g  
Water-----1 liter

PART B

Sodium Carbonate--60g  
Water-----1 liter

---

CWC2-----2'at 20oC

PART A

Pyrocatechol---20g  
Ascorbic Acid--10g  
Sodium Sulfite-10g  
Urea-----50-100g  
(100g suggested, but 50g works)  
Water-----1 liter

PART B

Sodium Carbonate--60g  
Water-----1 liter

---

PAAP-original Benton formula-----2'at 20oC

Ascorbic Acid-----18g  
Sodium Hydroxide-----12g  
Sodium Phosphate Dibasic--28.4g  
Phenidone-----.5g  
Water-----1 liter

---

APPENDIX A

DEVELOPER CHEMISTRIES

---

SM-6--"MAGIC"-----2'at 20oC

Ascorbic Acid-----18g  
Sodium Hydroxide-----12g  
Sodium Phosphate Dibasic--28.4g  
Phenidone-----6g  
Water-----1 liter

---

Holodev 602--original-----3'at 26oC

<u>PART A</u>	<u>PART B</u>
Pyrogallol-----50g	Sodium Carbonate--85g
Phenidone-----2g	Water-----1 liter
Benzotriazole-----.5g	
Sodium Sulfite-----130g	
Potassium Meta Bisulfite--50g	
Water-----1 liter	

---

Improved Holodev 602-----3'at 26oC

<u>PART A</u>	<u>PART B</u>
Pyrogallol-----50g	Sodium Carbonate--85g
Phenidone-----.5g	Sodium Hydroxide--34g
Benzotriazole-----.5g	Water-----1 liter
Sodium Sulfite-----130g	
Potassium Meta Bisulfite--50g	
Water-----1 liter	

---

Holodev Original with Pyrocatechol  
(replace 50g pyrogallol with 50g pyrocatechol in original formula)

---

Improved Holodev with Pyrocatechol  
(replace 50g pyrogallol with 50g pyrocatechol in improved formula)

---

Neofin Blue  
(no formula--used in pulsed transmission-- 1'20" 26oC)

---

APPENDIX B

BLEACH CHEMISTRIES

---

Pyrochrome-----Dilute 1:4

Potassium Dichromate--4g  
Sulfuric Acid(conc.)--4ml  
Water-----1 liter

---

CWPBQ2

PART A

Citric Acid-----30g  
Potassium Bromide--100g  
Water-----1 liter

PART B

p-Benzoquinone--4g  
Water-----1 liter

---

Ilford

Ferric Sodium EDTA--100g  
Potassium Bromide---10g  
Water-----1 liter

---

Ferric Nitrate-----Dilute 1:4

Glycerol (d=1.12g/ml)--20g (17.86ml)  
Phenosafranine-----300mg (watch hands)  
Ferric Nitrate-----150g  
Potassium Bromide-----30g  
Isopropyl Alcohol-----500ml  
Water-----500ml

---

N.J. Phillips

Ammonium Dichromate---20g  
Sulfuric Acid(conc.)--.5ml  
Water-----1 liter

---

THE "REAL" Fe EDTA or BENIGN or RCA  
30g Fe Na-EDTA  
30g POTASSIUM BROMIDE  
10 cc SULFURIC ACID OR 30g SODIUM BISULFATE  
1 l H<sub>2</sub>O

APPENDIX C

PYROCHROME DEVELOPER

Bleach	Dev. Time	Dev. Temp	Best Exp.	Results
PyroChrome	2 min	20 oC	10 sec. 240uJ/cm-cm	More orange than yellowish-gold
Holo Bl.	"	"	"	Didn't clear well (stained)
Ilford	"	"	"	Didn't clear well (stained)
CWPBQ2	"	"	"	No reconstruction in the original position

Final Results for PyroChrome Developer combinations

The rehalogenating bleaches aren't usable due to poor eff. and resolution. The pyro. bl. isn't of the desired color and speed.

ILFORD DEVELOPER

Bleach	Dev. Time	Dev. Temp	Best Exp.	Results
PyroChrome	3 min	20 oC	5 sec. 120uJ/cm-cm	Poor efficiency and resolution
Holo Bl.	"	"	"	No reconstruction
Ilford	"	"	"	No reconstruction
CWPBQ2	"	"	"	Poor laser reconstruction. Almost no efficiency. Wave mismatch and poor resolution.

Final Results for Ilford Developer Combinations

Not usable. The pyrogallol tanned too much for any efficiency. Reconstruction was deep red. This was probably due to emulsion swelling.

APPENDIX C

HOLODEVELOPER (ORIGINAL 602)

Bleach	Dev. Time	Dev. Temp.	Best Exp.	Results
PyroChrome	3 min	26 oC	10 sec. 240uJ/cm-cm	Good eff., res., and noise. Good color and depth.
Holo Bl.	"	"	20 sec. 480uJ/cm-cm	Good eff. and res. upon laser reconstruction.
Ilford	"	"	"	Same as above
CWPBQ2	"	"	"	Same as above
N.J Phillips (Ilford) Ammon.Dichr.	"	"	20 or 40sec 480uJ/cm-cm 960uJ/cm-cm	Not good color. Poor noise and efficiency is down as well as speed. Only 40'' is close to the desired color.

Final Results for HoloDeveloper Combinations

Great results. Not as good as CWC2 dev. but almost indistinguishable. HOLOdev/Chrome and HOLOdev/Holo bl. give the best results although CWPBQ2 and Ilford are just as good.

CWC2 DEVELOPER

Bleach	Dev. Time	Dev. Temp.	Best Exp.	Results
PyroChrome	2 min	20 oC	10 sec. 240uJ/cm-cm	Best white light reconstruction
Holo Bl.	"	"	20 sec. 480uJ/cm-cm	Almost as good as with the CWPBQ2 combination
Ilford	"	"	"	Same as above
CWPBQ2	"	"	"	Best in repositioning accuracy. Good SNR and eff. as well as res. in laser reconstruction.

Final Results for CWC2 Developer Combinations

The best of all the tested developers for the endoscope application. All of the combinations are good. Either this developer or the Holo. dev. can be used for the desired project. Both have good speed and eff.

APPENDIX C

IMPROVED 602 DEVELOPER

Bleach	Dev. Time	Dev. Temp.	Best Exp.	Results
PyroChrome	3 min	26 oC	10 sec. 240uJ/cm-cm	Green reconstruction. Fair SNR Poss. speed incr. Try ruby.
Holo Bl.	"	"	"	Poor eff. Reconstr. in deep red at diff. angle than orig. One step incr. Try ruby.
Ilford	"	"	20 sec. 480uJ/cm-cm	Same as above but no speed incr.

PYROCATECHOL-IMPROVED 602

PyroChrome	"	"	20 sec. 480uJ/cm-cm	5,10'' are orange. 20 is okay but orangish. Better eff. and res. than above.
Holo Bl.	"	"	"	Eff. is down. Fair res. but the plate is stained and bad SNR.
Ilford	"	"	"	Low eff. and wave mismatch toward deep red. Poor noise.

PYROCATECHOL-ORIGINAL 602

PyroChrome	"	"	40 sec. 960uJ/cm-cm	Fair color but not very close to the desired hue. Bad eff. and noise.
Holo Bl.	"	"	n/a	No reconstruction in laser light.
Ilford	"	"	n/a	No reconstruction in laser light.

Final Results for the Above Three Developer Combinations

All three combinations are pretty bad with Pyrocatechol-Imp. 602 being the best of the lot. Improved 602 with and without the pyrocatechol should be tried with the ruby--although the eff. is low. Pyrocatechol-Original 602 is useless in this application.

APPENDIX C

Developer Chemistry--pH

Holodev 602 (original)----- 9.4  
CWC2----- 8.8  
Improved Holodev 602----- 9.1

Bleach Chemistry---pH

	Pyrochrome	Holo	Ilford	N.J. Phillips	CWPBQ2
pH	2.35	6.2	3.7	1.3	

# Holoder 602 CW

A

Pyrogallol	50 g
Phenidone	0.5 g
(Benzotriazole	0.5 g)
Sodium Sulphite	30 g
Potassium Meta Bisulfite	50 g
Water	1 l

B

Sodium Carbonate	125 g
Water	1 l

# Holoder 602 pulsed

A

Pyrogallol	50 g
Phenidone	0.5 g
(Benzotriazole	0.5 g)
Sodium Sulfite	30 g
Potassium Meta Bisulfite	50 g
Water	1 l

B

Sodium Carbonate	85 g
Sodium Hydroxide	15 g
Water	1 l



**KODAK DEVELOPER SD-19a**

A Special Developer for Increasing Emulsion Speed.

**SOLUTION A**

Kodak Anti-Fog No. 2* (0.2% Solution)	5 fl. drams	20.0 ml
Hydrazine Dihydrochloride**	24 grains	1.6 grams
Cold water to make	1 ounce	30.0 ml

**SOLUTION B**

Water (about 125°F or 52°C)	16 ounces	500.0 ml
Kodak Elion Developing Agent	29 grains	2.0 grams
Kodak Sodium Sulfite, desiccated	3 ounces	90.0 grams
Kodak Hydroquinone	¼ oz. 8 grains	8.0 grams
Kodak Sodium Carbonate, monohydrated	1½ ounces	52.5 grams
Kodak Potassium Bromide	72 grains	5.0 grams
Add cold water to make	32 ounces	1.0 liter

\*To prepare a 0.2% solution of Kodak Anti-Fog No. 2, dissolve 2 grams (30 grains) in 1000ml (32 ounces) of hot distilled water.

\*\*CAUTION: Hydrazine Dihydrochloride is a skin irritant. Avoid contact of the powder or solutions with the skin or eyes. If contact does occur, wash with plenty of water immediately. It is advisable to wear rubber gloves and an apron while working with this formula.

Hydrazine Dihydrochloride is obtainable as Eastman Organic Chemical No. 1117, from laboratory supply houses, or on order through the Eastman Organic Chemicals Department, Distillation Products Industries, Division of the Eastman Kodak Company, 343, State St., Rochester, N.Y. 14650.

Dissolve chemicals in the order given. To prepare a working solution add 30ml (1 ounce) of Solution A to 1 liter (32 ounces) of Solution B (which is identical to Kodak Developer D-19) and mix thoroughly. The working solution should be prepared just before using.

The best speed increase is obtained by developing for the time required to give a fog value between 0.20 and 0.40. The developing time will depend on the temperature, processing equipment and agitation. In general, with intermittent agitation in a tray or tank, the correct time of development at 68°F (20°C) with conventional high speed emulsions is between 12 and 20 minutes. The optimum time can be determined for a particular emulsion by cutting a trial underexposure into three or more pieces and developing these pieces for a series of times ranging from 10 to 20 minutes. The time of development which produces the lowest fog density at which a satisfactory speed increase is obtained can be selected.

**KODAK DEVELOPER DK-20**

For Roll Films, Film Packs, Cut Films and Plates

Water (125°F or 52°C)	24 ounces	750.0 ml
Kodak Elion Developing Agent	75 grains	5.0 grams
Kodak Sodium Sulfite, desiccated	3 oz. 145 grains	100.0 grams
Kodak Balanced Alkali	30 grains	2.0 grams
*Kodak Sodium Thiocyanate	15 grains	1.0 gram
Kodak Potassium Bromide	7 grains	0.5 gram
Add cold water to make	32 ounces	1.0 liter

\*An equal weight of Potassium (Thiocyanate) Sulfocyanate may be substituted.

†Or Kodak Liquid, Use 1.5 mls for each gram.

Dissolve chemicals in the order given.

Average time of development for all Kodak Roll Film is about 15 minutes at 68°F (20°C) in a tank of fresh developer.

**KODAK DEVELOPER D-19**

A High Contrast High Energy Developer for Films & Plates

Water (125° or 52°C)	16 ounces	500.0 ml
Kodak Elion	30 grains	2.0 grams
Kodak Sodium Sulfite, desiccated	3 ounces	90.0 grams
Kodak Hydroquinone	115 grains	8.0 grams
*Kodak Sodium Carbonate, monohydrated	1½ ounces	52.5 grams
Kodak Potassium Bromide	75 grains	5.0 grams
Add cold water to make	32 ounces	1.0 liter

Dissolve chemicals in the order given.

This is a high-contrast, long-life, nonstaining tank or tray developer. It causes very little chemical fog, and thus produces exceptionally "clear" negatives. Originally developed for use with X-ray materials, D-19 is now recognized as an excellent developer for aerial films and for use with films and plates when high maximum contrast is desired, or when it is desired to obtain high contrast with a short developing time. Its good keeping qualities when used in tanks, and its rapid development rate make it particularly useful for press photography.

This developer is recommended for use at from 65°F (18°C) to 70°F (21°C) and best results will be obtained within this range. However, acceptable results will be obtained at somewhat higher and lower temperatures.

Increase the time about 25% for tank development.

◆ Available to make 1, 3½, and 5 gallons.

**REPLENISHER KODAK D-19R**

for Kodak Developer D-19

Water (125°F or 52°C)	16 ounces	500.0 ml
Kodak Elion	65 grains	4.5 grams
Kodak Sodium Sulfite, desiccated	3 ounces	90.0 grams
Kodak Hydroquinone	255 grains	17.5 grams
Kodak Sodium Carbonate, monohydrated	1½ ounces	52.5 grams
Kodak Sodium Hydroxide	¼ ounce	7.5 grams
Add cold water to make	32 ounces	1.0 liter

Dissolve chemicals in the order given.

Use without dilution and add to the developer tank in the proportion of 1 ounce of Kodak D-19R per 100 square inches of film processed (about 30 ml for each 8x10 film). The maximum volume of replenisher added should not be greater than the volume of the original developer.

**OBTAINING HIGHEST EMULSION SPEED**

With Kodak Films

There are a number of methods which have been proposed for increasing the effective sensitivity of a film beyond its normal rating. These emergency techniques are of particular value to the news photographer who is occasionally confronted with subjects which are inadequately illuminated under conditions which make it impractical to use flashlamps.

The methods of increasing film speed include intensifying the latent image between exposure and development, and the use of high-emulsion-speed-developers. For the latter method, one of the best formulas is Kodak Special Developer SD-19a, which can more than double the effective emulsion speed of high speed negative films. However, it should be noted that this higher speed is sometimes accompanied by increased graininess and higher fog level. This high fog level is, incidentally, unavoidable. If the development time is shortened to secure less fog, there will be no appreciable gain in emulsion speed.

judgment of the result : color accepted by the viewer, acceptability of small defects, amount of light accepted as optimal, contrast rendition etc. As it seems there is no standard at the moment, we used the ratio between the light reflected by an "absolute black" zone in the hologram (i.e. where there is no object wave) and an adjacent standard gray chart at 20 mm behind the film, measured with a simple comparison reflection densitometer, as an acceptable qualitative evaluation of the process; it can also be used for comparison between different processes.

Diffraction efficiency seems to be related to the density of the film after development, the optimum lying around  $D = 2.3$ . Of course, the output energy of the laser must be adapted to the reflection and (de)polarisation characteristics of the subject, but there seems to be a good relation between diffraction efficiency and macroscopic density, although they are basically quite different physical phenomena.

### Process

Hypersensitization. The relative merits of some sensitisation techniques found in the literature (see e.g. ref.<sup>9</sup>) were studied; a combination of trietanolamine sensitisation and pre-exposure was found to give good results. The film is led through a Gevamat DR2 dryer, in which a 3% TEA solution is replacing the normal water wash. This treatment allows one to increase the sensitivity (probably by the combination of three factors : the inherent amino-sensitisation; the absorption of some water : water dipping alone increases sensitivity, too<sup>10</sup>, and washing out of some of the sensitizing dye, so the adsorption of the emulsion is lower, and also increases the efficiency. The influence of hypersensitisation can be seen on the diagram (curve 2, Figure 3).

The dynamic range of the image forming standing waves in reflection holography is larger than strictly necessary for adequate image formation. At the other hand, the holographic image is superimposed on a photographic one (direct reflection) that can be considered as noise; finally, double reflections (almost unavoidable, see later problems) give rise to macroscopic density variations ("wood structure") that will locally influence both color and diffraction efficiency. All those "photographic" irregularities can be alleviated by carrying out a weak and uniform white light pre-exposure, e.g. by the use of a high-quality enlarger. In Figure 3 the H & D curve for white light is given (curve 4). A uniform density of 0,4 or even slightly higher can be accepted. Influence of pre-exposure can be seen on curve 3, which is the curve used in practice.

Development. The basic developer is based on the formulation :

L-ascorbic acid	10 grams
4-aminophenol sulfate (metol)	2,5 g
Sodium carbonate, anhydrous	45 g
Sodium EDTA (Na salt of ethylene diamine tetra acetic acid)	2 g
Potassium bromide	0,5 g
Distilled water to	1 liter

This formulation can need some adjustment in function of the emulsion batch and/or the age of the material.

Temperature control is important; changes of more than 1°C must be avoided. Develop 4 minutes with constant agitation. The energy required can be derived from the diagram (curve 3) for development at 20°C. Develop maximum 3 sheets of 30 x 40 cm in 200 cc of developer, less if visible oxydation occurs. Wash in running water for about 30 seconds, then rinse in distilled water.

Bleach. The classical reversal bleach is used, without prior fixing :

Ammonium dichromate	3 g
Sulphuric acid, concentrated	1,5 cc
Distilled water to	1 liter

Bleach until clear, then keep the hologram one more minute in the bleach bath. Wash in running water.

Drying. Drying is best carried out with the help of another Gevamat DR2, the tank being filled with a solution of 1 cc Agepon flow agent pro liter of distilled water.

Finish. Dehydrate in a stove at 70° for at least 30 minutes (also hardening the gelatin). Backing is normally done by spraying an index-matching varnish on the gelatin side and covering it with a matt black paint. Trials should be effectuated to see if the solvents do not influence the color of the result; even when using the same brand of paint,

10E75

$\approx 5 \mu\text{s}$   
 $k = 694 \text{ nm}$

Febr 6, 87

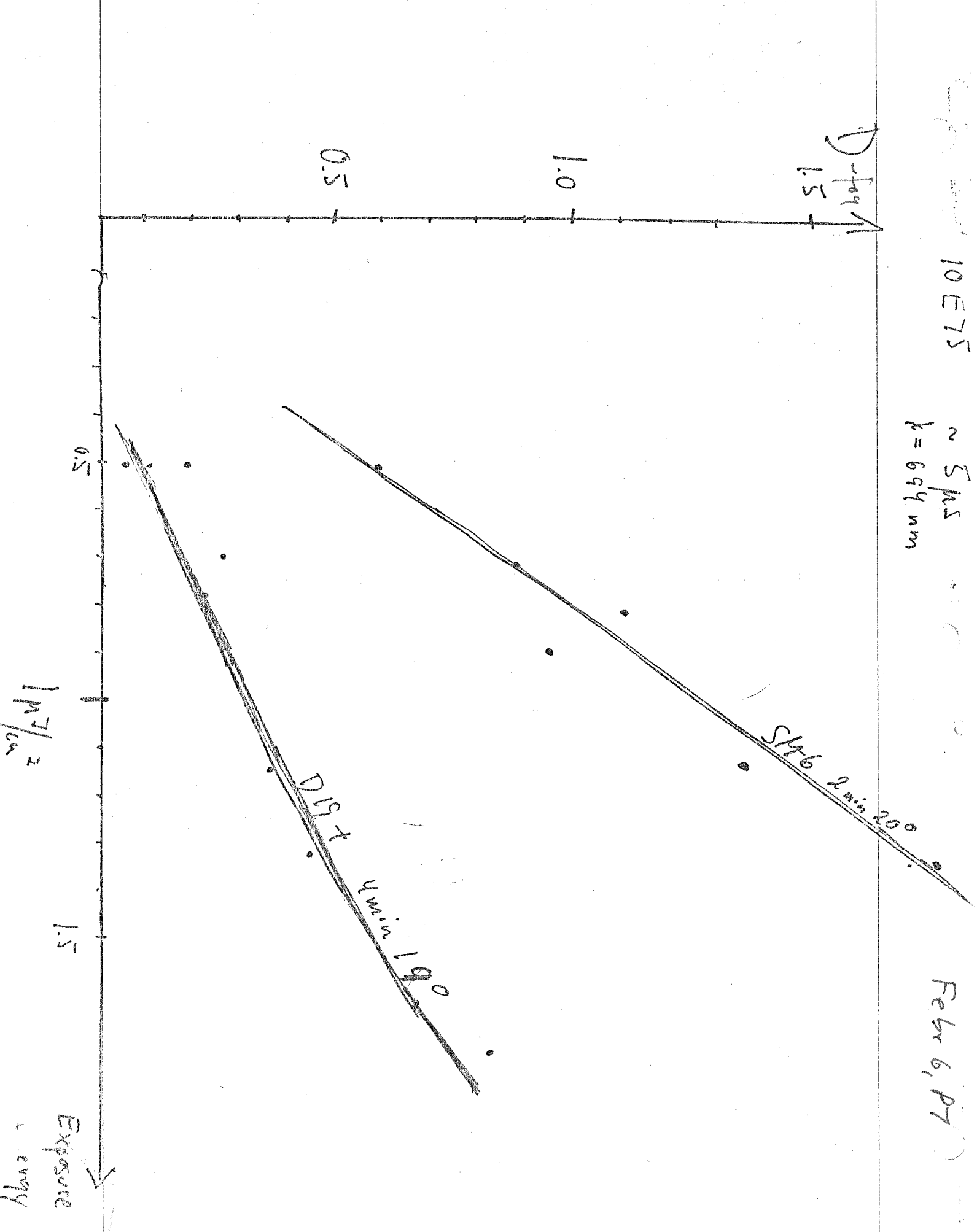

Holographic Techniques Investigation

Tests conducted by Patrick Sinopole,  
Ed Wesly, and Hans Bjelkhagen.  
Report compiled by Patrick Sinopole.  
Department of Biomedical Engineering  
Northwestern University  
Evanston, Illinois  
February- March 1987

